

FIRE SUPPRESSION & DETECTION SYSTEMS

For U.S. Coast Guard
Inspected Vessels

FIREBOY - XINTEX

USCG / ABS Approved
Marine & Offshore
Yachts & Ships

WHY CHANGE

from CO2 to Clean Agent

Shipboard Fires Are Major Threats To Safety

Of all the perils at sea, one of the most dangerous is fire. Difficult to deal with and potentially deadly, fire leaves the crew and passengers caught between two unforgiving elements. There's no local fire department to call, it's up to the crew to control the fire. Fire-fighting at sea and on water is especially demand-

ing. The complexity of design and component requirement of a traditional marine CO2 system is there to achieve system safety, however, the results of an accidental discharge can be catastrophic.

With so many levels of safety being required to be put in place, even

on the smallest installation, CO2 systems can add significant extra weight and cost to the overall build of any vessel. Imagine being able to replace most of that expensive, heavy pipe work and see what you could do with the extra space generated by not having all of those extra cylinders in storage!

Typical 'Marine' CO2 System

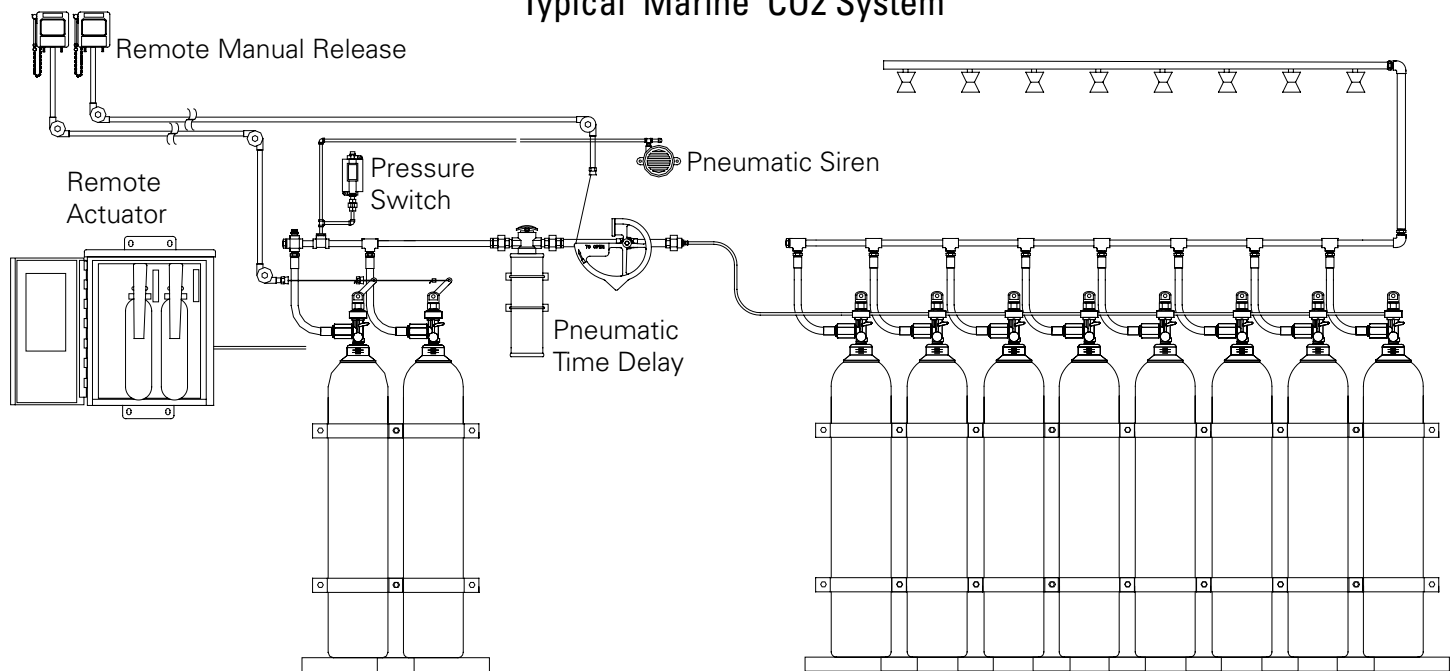

Agent	Agent Weight	Cylinder Volume	Number of Cylinders	Footprint	Cube	Total Weight
	Lbs	Lbs	Each	ft ²	ft ³	Lbs
Halon 1301	476	65.0	1	3.2	17.7	882
Carbon Dioxide	802	18.0	8	6.5	31.8	2205
FE-13	937	18.0	9	6.5	35.3	2646
FM-200®	703	93.2	1	4.3	24.7	1323
Novec™ 1230	822	97.2	1	4.3	24.7	1323
Inergen	705	21.7	19	14.0	95.3	4409
Water Mist	19842			3.8	243.7	6393

Typical 'Marine' CO2 System

This table shows the typical usage of cylinders and chemical for a 500m³ system. While there is comparable weight of the Chemical Agent between CO₂ and the Clean Agents, the number of cylinders required to store the chemical agent is reduced by a factor of 8:1, thereby giving a 40% reduction in system weight.

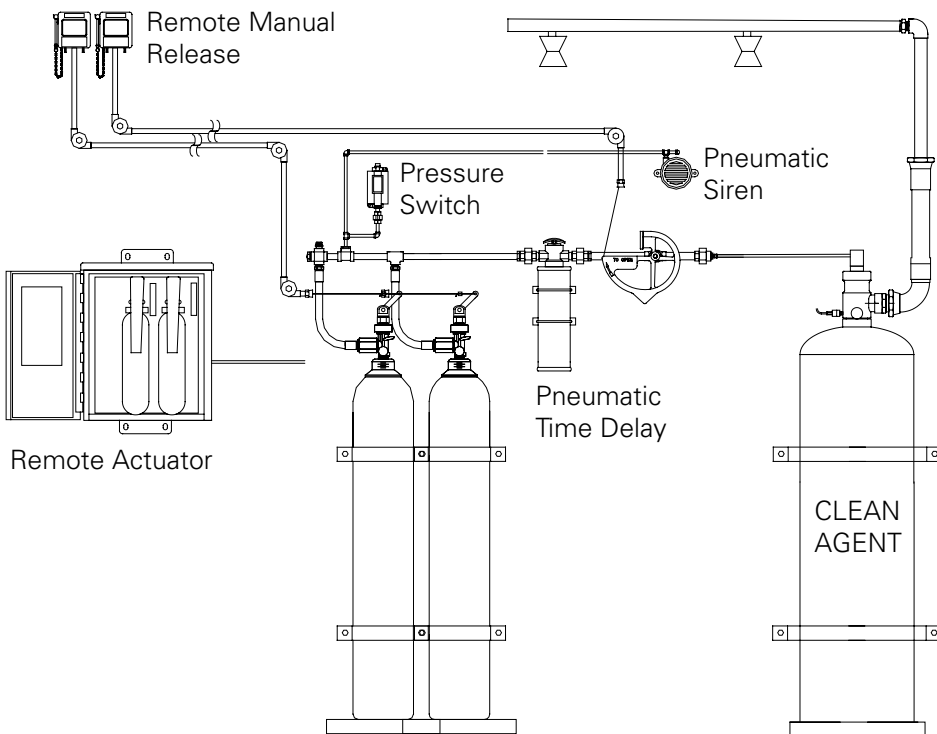

SAFE For People, Equipment, and Environment

Today's modern 'Clean Agents' are approved worldwide for use in 'Occupied' spaces, however even with these safe chemicals, similar design rules have to be maintained to comply with IMO SOLAS requirements. Just replacing the chemical agent will have a profound effect on safety.

The issue with safety is not a question of whether or not carbon dioxide can cause injury or death at the concentrations used in total flooding systems. Everyone agrees the agent is nearly instantly lethal at those concentrations. The issue is whether or not the safeguards built into the systems coupled with the requirements of standards and regulations are adequate to assure safety to those who work around, visit, or transit areas fitted with carbon dioxide systems.

CLEAN AGENTS

Remove Heat Energy, Not Oxygen

Every second counts when a fire occurs on-board. Clean Agent systems reach extinguishing levels in less than 10 seconds. Since even a few seconds can mean the dif-

ference between survival and a life destroying catastrophic fire, changing to the Fireboy FES system could give you a crucial margin of safety. That's why you need a fast, people-

safe and effective fire suppressant: Clean Agent Waterless Fire Protection from Fireboy-Xintex.

Perfect For New Builds and Refits

The 'Fireboy' FES System provides the perfect choice for both new builds and refits and is currently the system of choice for many Commercial and Superyacht builders

around the world. With the ability to eliminate a vast amount of industrial components, the advantages in both weight and cost are evident.

Effective on Class A, Class B and Class C fires, Clean Agent gas extinguishes fires quickly through a combination of chemical and physical heat removal. It does not smother flames by removing oxygen. Clean Agents remove heat energy from fire, not oxygen from the environment. Heat is absorbed from the flame zone and interrupts the chemical chain reaction of the combustion process. When fires are stopped this fast it minimizes the risk of explosion and extensive damage.

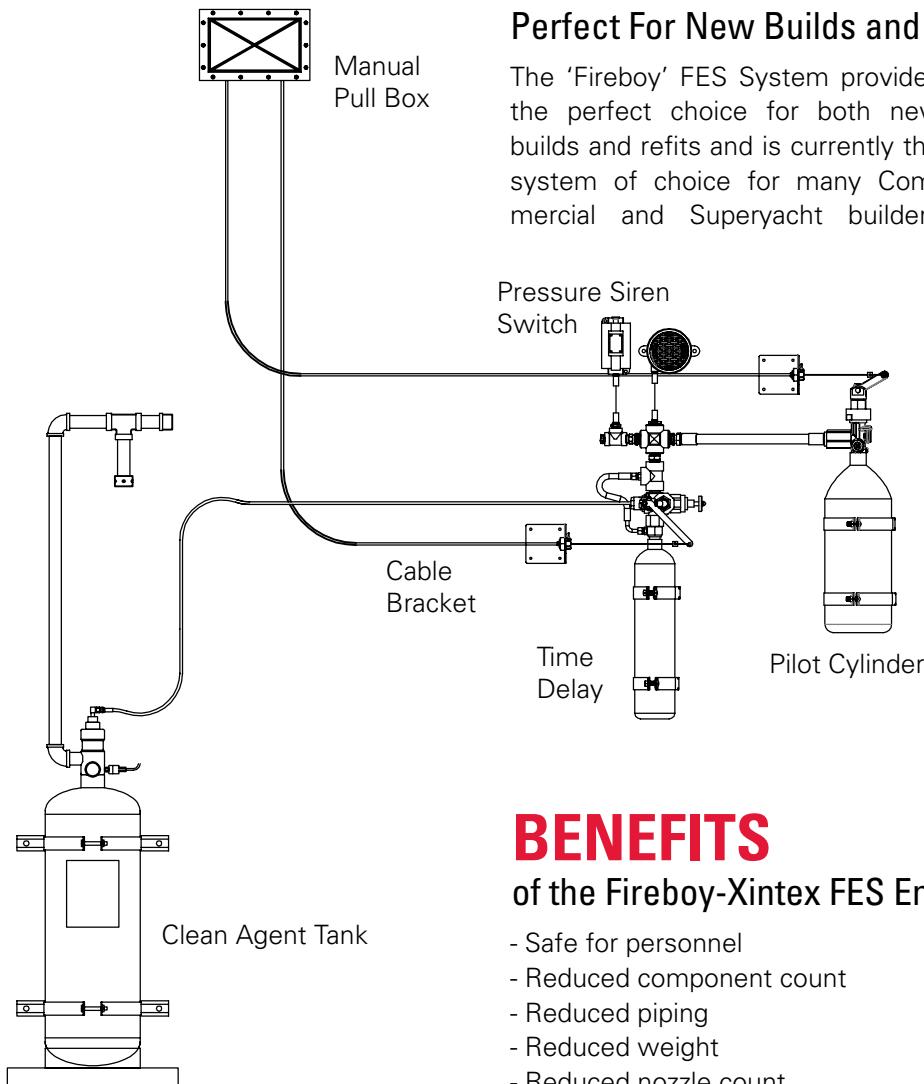

BENEFITS

of the Fireboy-Xintex FES Engineered System

- Safe for personnel
- Reduced component count
- Reduced piping
- Reduced weight
- Reduced nozzle count
- Ease of installation
- Cost effective replacement for CO2
- System monitor integration
- Multiple discharge panel facility
- Lower stored pressure

In the case of carbon dioxide systems, the beneficiary of the risk and the risk taker are nearly always different parties. The decision to employ carbon dioxide systems is never made by those who are ultimately exposed to the danger of death or injury. Instead it is made by the owner or owner's representative and it is to the owner that the benefit of a cost savings accrues. In this case, it is the workers or other persons exposed to the possibility of an accidental discharge of the carbon dioxide system who assume the risk.



CLEAN AGENTS are approved by ALL Notified Bodies

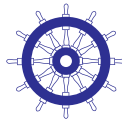

HFC-227ea/FM-200®

FM-200® was originally developed to replace ozone-depleting fire suppressants such as halon 1301. FM-200® does not deplete stratospheric ozone. It has been proven safe for people through extensive pharmacological testing rivalled by no other fire suppressant. Many fire suppressants cause collateral damage to the equipment and the assets they were supposed to protect. But not FM-200®. It deploys quickly and cleanly without leaving any residue or causing collateral damage. FM-200® is the world's most trusted choice in waterless fire protection.

Unlike carbon dioxide (CO₂) and HCFC 124, FM-200® is safe for people and can be used in occupied spaces on all types of vessels. FM-200® has been proven to be so

safe that the chemical is approved as a propellant for pharmaceutical inhalers. Unlike many other fire suppressants, FM-200® does not break-down or metabolize when inhaled, which allows quick removal through normal respiration once the individual is no longer exposed.

Novec™ 1230 Fire Protection Fluid

Novec™ 1230 is a clean agent fire suppression solution from 3M. 3M Novec™ 1230 offers an environmentally sustainable alternative to fluorinated chemical suppression agents which does not compromise on performance or asset protection.

3M Novec™ 1230 offers rapid fire suppression while alleviating installation and safety concerns which could be present in alternative inert gas solutions.

Fire suppression applications often include the presence of people, so life safety is a critical issue when selecting a fire suppression product. 3M Novec™ 1230 fire suppression fluid is both low in acute toxicity and is a highly efficient fire extinguishing agent. This means that 3M Novec™ 1230 fluid is designed to put out fires long before it reaches a level of concentration that could adversely affect humans, allowing ample time to egress the protected space. In fact, even at relatively high extinguishing concentrations, 3M Novec™ 1230 fluid offers the widest margin of human safety over CO₂ and inert gas.

3M Novec™ 1230 is a registered trademark of 3M, used under license. FM-200® is a registered trademark of Dupont, used under license.



FIRE SUPPRESSION

Fireboy Xintex FES Engineered System

Fireboy-Xintex FES Systems are designed based on the requirements of: USCG, MSC Circular 848/1267, and NFPA 2001.

Fireboy-Xintex Clean Agent Systems consist of DOT approved steel

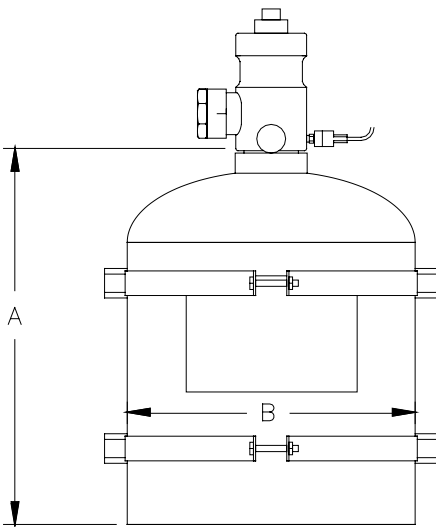

cylinder(s) equipped with a brass valve and internal siphon tube, and filled with HFC-227ea (FM-200) Extinguishant, then super-pressurized to 360 PSI at 70°F. Multiple cylinders may be manifolded together in identical size and fill density to achieve coverage for the protected space. An embossed nameplate is perma-

nently attached to the manufactured cylinder containing agent weight, tare weight, and gross weight, fill density and fill date.

8 cylinder sizes are available, as listed below. A factory installed (optional) liquid level indicator is available on the 106L through 343L cylinders.

Part Number	Tank Capacity Lb	Outlet Size in.	Dim A Nominal in. (mm)	Diameter in. (mm)	Empty Weight Lb (kg)
FES-8L-227	9-17	1 in. NPT	12 (304)	10 (254)	32.6 (14.8)
FES-16L-227	18-35	1 in. NPT	19.8 (502)	10 (254)	40.6 (18.4)
FES-32L-227	36-70	1 in. NPT	32.8 (833)	10 (254)	57.5 (26.1)
FES-52L-227	58-114	2 in. NPT	23.5 (596)	16 (406)	108.3 (49.1)
FES-106L-227	117-233	2 in. NPT	40.2 (1021)	16 (406)	158.3 (71.8)
FES-147L-227	163-324	2 in. NPT	53.3 (1354)	16 (406)	198.2 (89.9)
FES-180L-227	199-396	2 in. NPT	64.3 (1634)	16 (406)	233.2 (105.8)
FES-343L-227	379-756	3.5 in. Flare	57.7 (1466)	24 (610)	456 (207)

Designs can be supplied in the following formats:

Autocad 2010 (2D)
Solidworks (3D)

Cylinder Stored Pressure:

CO2 2025 PSI
FM-200® 360 PSI
Novec™ 1230 360 PSI





USCG and ABS **APPROVED**

Fireboy-Xintex will provide design assistance to provide the best solution to your Clean Agent Fire Suppression requirements. Our extensive Fire Extinguisher Engineering and Manufacturing expertise covers 5 decades in the Marine Industry with the acknowledgement of Fireboy as innovators and supplier of top quality marine safety products. Our systems

are in use on Commercial, Military, Yachts, Cruisers, and boats of all sizes and styles. When it comes to reliability, no one else has earned the high level of trust that we have.

For USCG Boats, there are two basic configurations of Clean Agent Fire Suppression systems acceptable to the marine market. Hazard areas un-

der 6000 cubic feet, may be installed without time delays and warning devices. For areas greater than 6000 cubic feet we include a 30 second time delay, and pneumatically activated warning sirens.



All systems are designed to IMO SOLAS CH II-REG 7 MSC.CIRC 848 & 1267.

USCG system components are in compliance with the Fire Protection requirements of Marine Equipment Directive (MED) 96/98/EC as modified by Directive 2002/75/EC.

Drawings and designs to comply with:



FIREFOY - XINTEX

FIRE SUPPRESSION

Fireboy Xintex FES Engineered System

SHIP HAZARDS

Fireboy-Xintex Systems have been used for suppressing fires in several locations on a ship. Typical shipboard hazard locations include but are not limited to:

Engine Rooms	Machinery Spaces
Flammable Liquids Storage	Paint Lockers
Generator Rooms	Electrical Control Rooms
Pump Rooms	Galley

Design concentrations will vary based on the specific hazard being protected. Our design team will calculate the exact quantity of clean agent HFC-227ea extinguishant required to meet the specific agent requirement.

The FES System is activated several ways determined on the specific application:
Thermally with a quartzoid bulb Manually
Pneumatic A combination of the listed designs

Our Manual Activation Station was designed with safety in mind to reduce accidents on board by eliminating glass found in typical pull stations, by designing a USCG Approved pre-scored Plexiglas window. In the case of a fire, no one has to locate a hammer, or worry about shattered glass. Our conduit encased high-temperature manual discharge cables eliminate the time consuming and costly expense of corner pulleys, cutting conduit and running cable from the pull station to the cylinder.



FIRE DETECTION

Fireboy Xintex Marine Safety System

MARINE & OFFSHORE Analog Addressable Fire Alarm Control



Fire Alarm Control Panel Model: Elite RSM

Host up to 126 Apollo fire detection devices per loop. Fireboy-Xintex Elite RSM uses leading edge microprocessor technology to provide a flexible control system with high reliability and integrity. Designed for all small to medium sized vessels, Elite RSM control panels can be expanded and networked to handle 16 independent loops.

With its large graphical display, ergonomic button, and indicator layout, the Fireboy-Xintex control panel is simple and straightforward to understand for installers, commissioning personnel, and boaters alike.

Two Loop Panel conforming to USCG Requirements for the protection of accommodation areas and machinery spaces.

Features

- 16 zonal LED indicators
- 2 programmable NAC circuits with internal synchronization support
- 5 programmable inputs
- 3 programmable relays
- 5.25 A power supply
- Large graphic display
- Real time clock
- Compatible with eMatrix graphics annunciator
- Powerful, network wide cause and effects (500 total). Fully user programmable by point or zone

- Can be networked with additional RS and/or Elite panels
- Compatible with eView Annunciator
- Programmable through a PC connection to the panel
- Sensitivity adjustment and drift compensation
- Apollo Protocol
- Stores 1000 last events in event log
- Stylish compact enclosure
- Model ranges include with or without a dual-line internal DACT

Configuration Features

- Comprehensive day/night mode facility
- Programmable one touch test mode
- Powerful and versatile cause and effect programming
- Cause and effect wizard including cause and effect action, disablement configuration, and test mode configuration

FIRE DETECTION

Fireboy Xintex Marine Safety System

TECHNICAL

Panel Dimensions

14.5" w x 18.9" h x 4.25" d

Weight

20 lbs (without batteries)

Construction

16 AWG steel

Enclosure Finish

BS 00 A 05 light grey textured

Mains Voltage Supply

110 VAC 60 Hz

Display

8 lines of 40 characters graphic LCD

Power Supply DC Rating

24 V 5.25 Amps

Aux 24V Supply

Fused at 500 mA

Battery 24 Hour Standby

9 Ah 12V (2 per panel) (non-networked)

Fault Contact Rating

30 V DC 1 Amp

Alarm Contact Rating

30 DC 1 Amp

NAC Output Rating

3.1 V across both channels, 2.3 V across any one

Detection Loop

250 milliamp output

Detection Protocol

Apollo Discovery

Printer Port

Serial RS232

Serial Expansion Port

Serial RS485

PC Port

Serial RS232

Network Connection

Optional network cards allow the use of e-net networking or VES networking

NAC Synchronization

Internal Support

NAC Protocols

Apollo, System Sensro, Wheellock, Gentex, Amesco

USCG Approved Analogue Addressable Devices

- Smoke
- Heat
- Heat/Smoke
- Manual Pull Stations
- Sounder Bases
- Sounder Beacon Bases
- Relay Bases
- Beacons
- Sounders
- Intrinsically Safe Devices
- Line Monitors

The manufacturer reserves the right to amend specifications without prior notice.

Apollo's wide selection of smoke and heat detectors, manual pull stations, sounders and beacons are available to complete your system.





Elite RSM

REPEATER PANELS

The Elite RSM fire alarm annunciator provides a simple and convenient method of extending the controls and indications of the Elite RSM fire

alarm control panel to other locations. The large, graphic liquid crystal display and high brightness LED indicators duplicate the indications on

the Elite fire alarm control panel at up to 15 additional locations via a simple, two-wire serial data connection.

The Elite RSM is available in either a 24V DC powered option (which can be powered via an additional 2 cores from the Elite RSM control panel/local 24V DC supply) or a 110V powered option with local battery back up.

Up to 15 Elite RSM repeater annunciators can be connected to each control panel on the Elite RSM network. Ideal where multiple points of indication and/or controls are required, such as crew's quarters and engineers cabins.





***FIREBOY* - XINTEX**

Fireboy-Xintex.com

*Fireboy-Xintex, Inc. . P.O. Box 152
Grand Rapids, Michigan 49501 . 616.735.9380*

*Fireboy-Xintex, Ltd . Unit 10 Holton Road, Holton Industrial Estate
Poole, Dorset BH166LT UK . 44 (0) 845 389 9462*