

FR-1000/2000 Installation Manual



Introduction

Thank you for purchasing the FR-1000/2000 Fire Alarm Monitor. Fireboy-Xintex, Inc. is very proud to be able to provide this product to you. You have selected a capable system designed to provide years of reliable service under the most demanding conditions.

The FR-1000/2000 Fire Alarm Monitor is a versatile, compact, modern, stylish, user-friendly intelligent network system. Our Research and Development Team have developed this system specifically for the marine environment using proven techniques and materials, which will ensure a long life at sea.

The FR-1000/2000 provides features found only in expensive computer-based systems on mega-yachts, but does so for a fraction of the cost. It is an economical and capable alternative to simplistic monitoring systems. The FR-1000/2000 allows builders and retrofitters to offer a system with maximum functionality.

Installation

WARNING!!

This equipment is NOT intended for use in the following locations and requiring exceptional degrees of protection

Locations requiring an exceptional degree of protection means - a location exposed to weather, seas, splashing, pressure-directed liquids, or similar moisture conditions. These locations include--

- (1) On deck;
 - (2) A machinery space;
 - (3) A cargo space;
 - (4) A location within a galley or pantry area, laundry, or water closet which contains a shower or bath; and
 - (5) Other spaces with similar environmental conditions.
-
1. The FR-1000/2000 should be mounted in a convenient location, preferably where the visual indicators may be readily seen. To install the display, you must first remove the screw on bezel.
 2. Next, drill a 2-1 /16" diameter hole into the panel. Slip the instrument through the hole and secure with the threaded bezel.
 3. Install the detectors using directions included with each detector.
 4. Wire the Battery + and Battery – leads to an appropriate voltage source (9-30Vdc)
 5. On the FR-1000 wire the detector loop to the White and Black wires connected to White (Zone +) and Black (Zone –). See following pages for diagrams.
 6. The FR-2000 has two zones. Wire the first zone the same as the FR-1000 and the second zone to Blue (Zone +) and Black (Zone -).
 7. The buzzer comes pre-wired to the mating harness so no additional wiring required.
 8. The pre-wired buzzer may be replaced with an alternative indicator. The current draw of the device must not exceed .75A or 750mA.

FR-1000 Harness Wiring

Black = Battery -

Yellow = Buzzer +

White = Zone +

Not Used

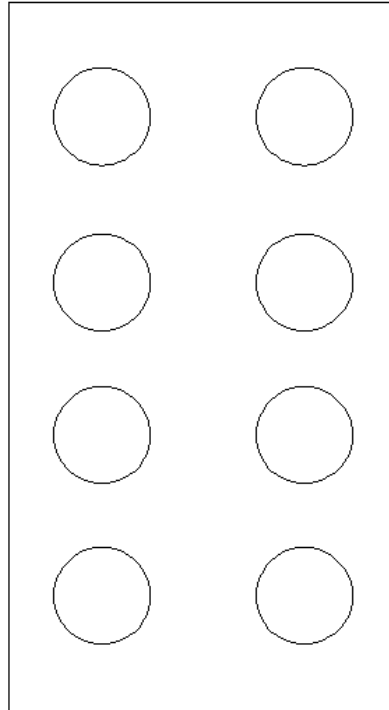

Red = Battery +

Purple = Buzzer -

Black = Zone -

Not Used

FR-2000 Harness Wiring

Black = Battery -

Yellow = Buzzer +

White = Zone +

Blue = Zone +

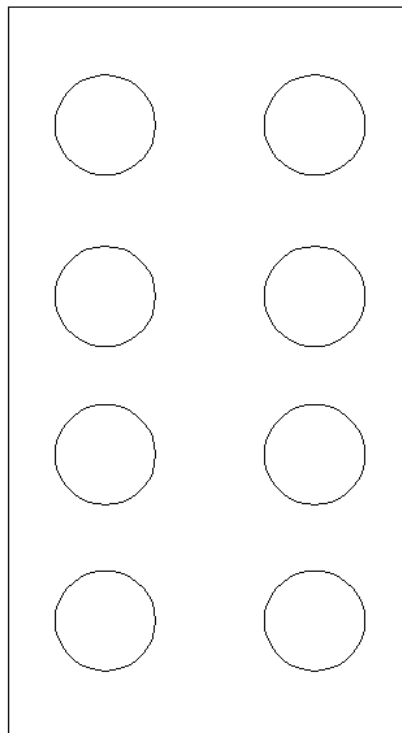

Red = Battery +

Purple = Buzzer -

Black = Zone -

Black = Zone -

Connecting One Sensor per Zone

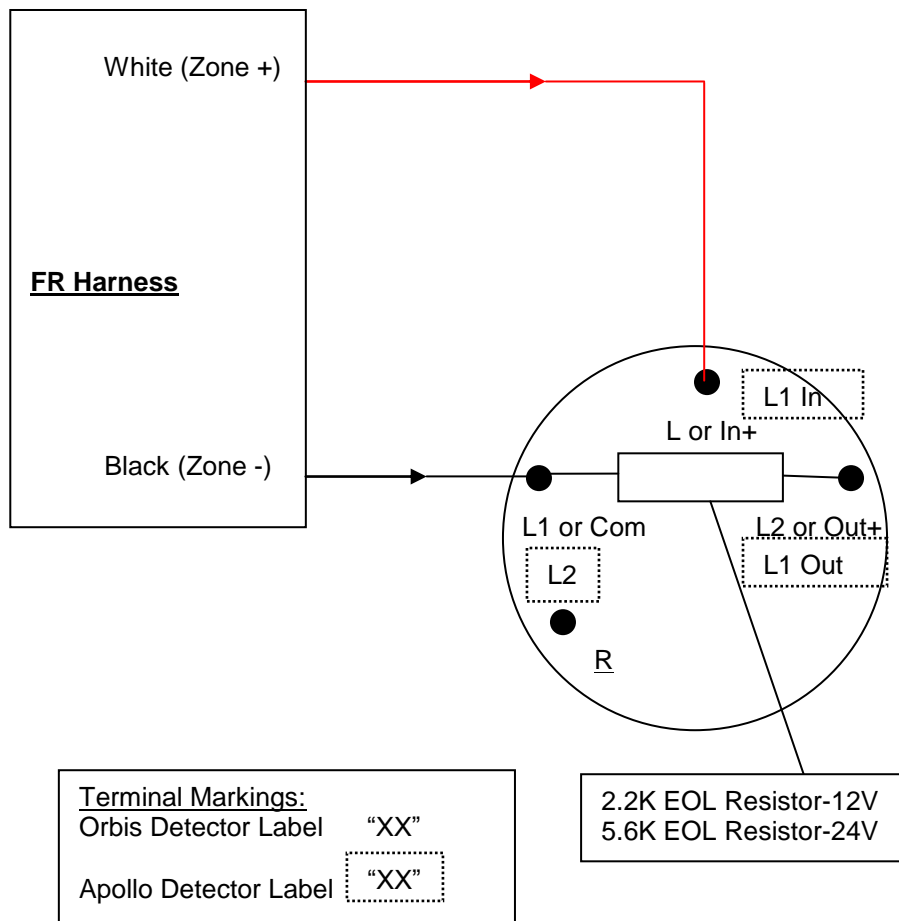

Wiring for door switches or contact sensors

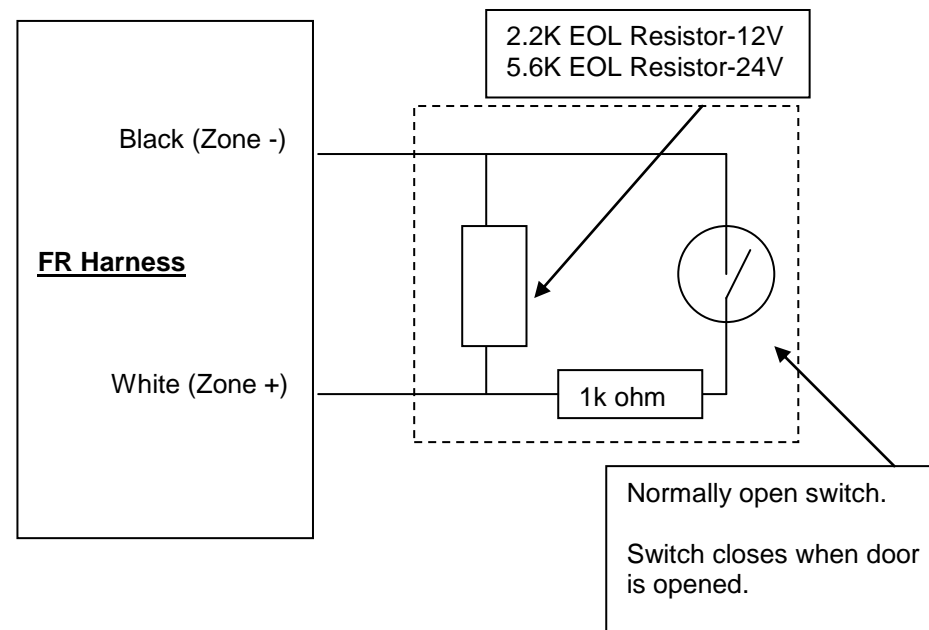

Connecting Multiple Sensors Per Zone

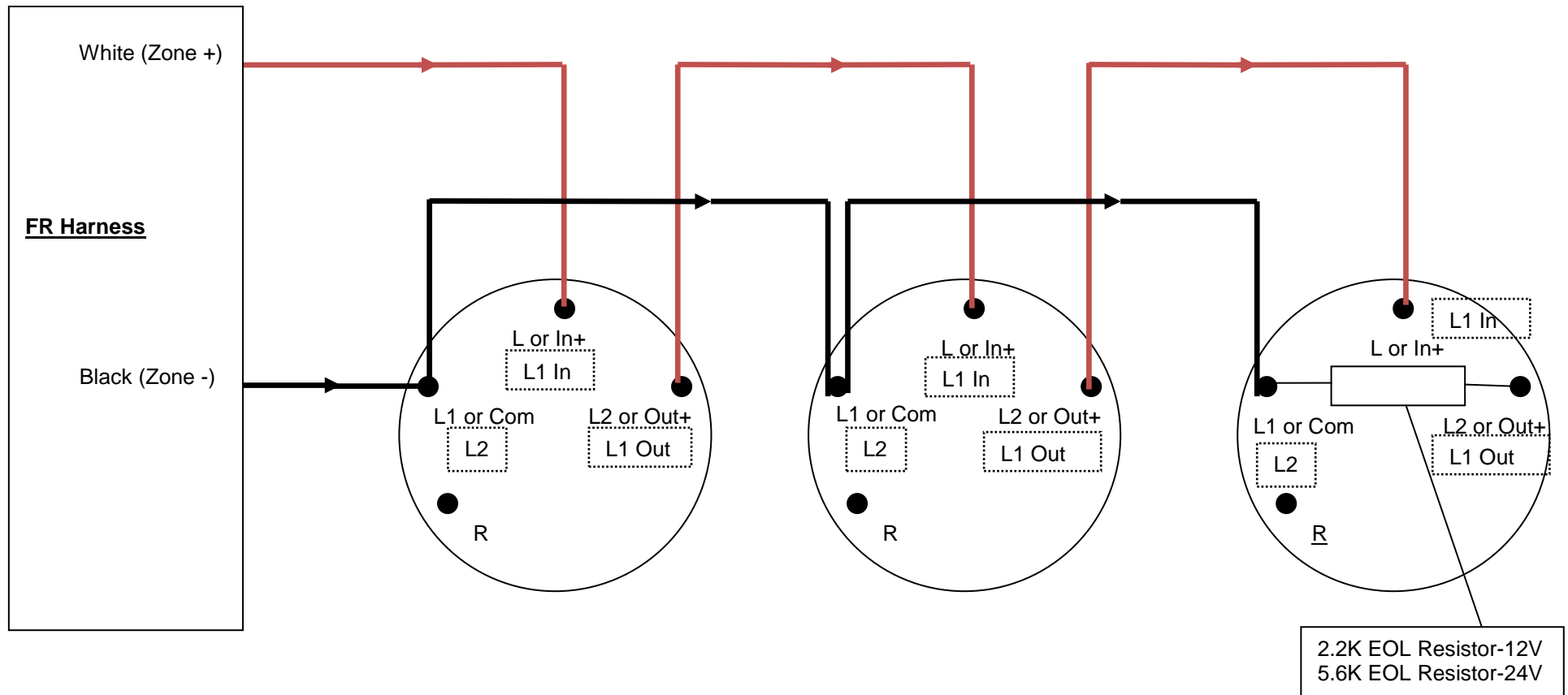

Terminal Markings:
 Orbis Detector Label "XX"
 Apollo Detector Label "XX"

Operation

“OK” LED On = system is all ok.

“FAULT” LED On = either open or shorted smoke detection cable or sensor.

If there is a short on the line:

If a short is detected on the line the “OK” LED will turn off, the “FAULT” LED and alarm will turn on, the Sensor Output will also be turned off. When the “SILENCE / RESET” button is pushed the “FAULT” LED will turn off and the zone “OK” LED will flash for one minute, after the one minute delay the Sensor Output will turn on again to check the line. This procedure will repeat until the short is removed.

If the line is open circuit:

If an open circuit is detected on the line the “OK” LED will turn off, the “FAULT” LED and alarm will turn on. When the “SILENCE/RESET” button is pushed the alarm will be muted. When the system detects the EOL resistor the “FAULT” LED will turn off and the “OK” LED will turn on.

“FIRE” LED On = A sensor has detected smoke or heat.

SILENT / RESET Button:

This button will mute the audible alarm and reset the sensors.

TEST Button:

If the TEST button is pressed for three seconds the unit will go into Test mode. All LED'S and the alarm will turn on for five seconds.

Electrical Specifications FR-1000/2000

Minimum (alarm current) = 10mA

Operate voltage = 9 - 30vdc

Maximum current per zone = 320mA (including EOL)

Siren/Buzzer output = 12vdc @ 800mA

Supply voltage @ 12vdc

Maximum sensors = 14 per zone

Must use 2k2 EOL resistor

Supply voltage @ 24vdc

Maximum sensors = 8 per zone

Must use 5k6 EOL resistor



One (1) Year Limited Warranty

This Warranty is in lieu of all other express or implied warranties. Seller warrants title, materials, and workmanship on Fireboy equipment and assigns, the original manufacturer's warranty on those components manufactured by others, as permitted. Seller's warranty shall be for a period of (1) one year from the date of sale to the ORIGINAL CONSUMER Fireboy-Xintex, Inc. does not assume the costs of removal and/or installation of the product or any other incidental costs which may arise as a result of any defect in materials or workmanship. Any non-conforming equipment returned to the Seller at Buyer's expense and risk shall be repaired or replaced at Seller's option, provided that: (a) the product has not been subjected to abuse, contamination, neglect, accident, incorrect wiring not our own, improper installation or servicing, or used in violation of the instructions furnished by Fireboy-Xintex, Inc. (b) the product has not been repaired or altered by anyone other than Fireboy-Xintex, Inc. (c) the serial number has not been removed, defaced, or otherwise changed (d) the product is determined to contain defective materials or workmanship: and (e) use of the product is discontinued upon discovery of defective materials or workmanship and Fireboy-Xintex Inc. is notified immediately.

ANY WARRANTY IMPLIED BY LAW, INCLUDING WARRANTIES OF MERCHANTABILITY OF FITNESS, IS IN EFFECT ONLY FOR THE DURATION OF THE EXPRESS WARRANTIES, OR TO ASSUME FOR FIREBOY/XINTEX, INC., ANY OTHER LIABILITY IN CONNECTION WITH THE SALE OF ITS PRODUCTS. FIREBOY/XINTEX, INC. SHALL BE NOT LIABLE FOR THE LOSS OF USE, REVENUE, PROFIT, INJURY OR ANY OTHER CONSEQUENTIAL OR INCIDENTAL DAMAGES. BUYER IS NOT RELYING ON SELLER'S JUDGEMENT REGARDING BUYERS PARTICULAR REQUIREMENTS, AND HAS HAD AN OPPORTUNITY TO INSPECT THE PRODUCT TO BUYER'S SATISFACTION.

All technologies, design and Intellectual Property is owned by
Manufactured for

Fireboy-Xintex, Inc.
Safety Systems

P.O. Box 152 Grand Rapids, MI USA 49534
O-379 Lake Michigan Dr. Grand Rapids, MI USA 49534 616-735-9380

Fireboy-Xintex, LTD
Safety Systems

Unit 10 Holton Rd. Poole, Dorset BH16 6LT UK +44(0)845 389 9462
www.fireboy-xintex.com