



3M™ Novec™ 1230 Fire Protection Fluid

MAEXXXNVC-BXXXX

Manual/Automatic/Electric, 175°F (79°C) Bulb

MAEXXXNVC-30BXX

Manual/Automatic/Electric, 155°F (68°C) Bulb

MAEXXXNVC-33BXX

Manual/Automatic/Electric, 135°F (57°C) Bulb

Sizes: 25-1800 cu. ft.
0.7-51.0 cu. m

Owner's Manual
&
Installation Instructions



APPROVED

Project ID: 0003063147

Read and comply with all instructions, warnings and limitations before installing, servicing or removing this device.

Additional copies of this manual are available at no charge by contacting the manufacturer, distributor or dealer. Fireboy-Xintex reserves the right to change features without notice.

General Information	3
Specifications	5
Operation of Fireboy Fire Extinguisher	6
Installation Instructions	8
Before Installation	8
Selecting Location	8
Mounting Fireboy System	9
Electrical Connections to Release Panel	11
Arming the Fireboy MAE Fire Extinguisher	13
Installation Checklist	14
Maintaining Fireboy Fire Extinguisher	15
Maintaining the Extinguisher Releasing Circuit	15
Health and Safety	16
Safety Data Sheet	18
Returning Fireboy-Xintex Equipment	23
Recharging Fireboy Extinguishers	23
3 Year Limited Warranty	24
Appendix A: Optional Cable Installation (P/N: E-4209-XXX, XXX = Length in Feet)	25
Routing Cable	25
Legend Plate and T-Handle	26
Connecting Cable to Cylinder	28
Appendix B: Disconnection and Inspection of Optional Manual Discharge Cable	31

General Information

Fireboy Manual/Automatic/Electric (MAEXXXNVC-BXXXX) series Fire Extinguishing Systems are manufactured for a broad range of applications, including industrial and commercial uses. This booklet is intended to outline the proper installation of the system. If further technical advice is required, information is available by contacting Fireboy-Xintex.

Fireboy 3M Novec 1230 Systems are FM approved for use in normally occupied spaces for A, B, and C class fires.

The National Fire Protection Agency defines normally occupied enclosure or space as “an enclosure or space where one or more persons are present under normal conditions.” (NFPA-2001).

SDS Sheets are available at no charge from the manufacturer and online at www.fireboy-xintex.com.

Referenced Agencies:

Bureau Veritas
3663 N. Sam Houston Pkwy. E., Suite 200
Houston, TX 88034

National Fire Protection Agency
1 Batterymarch Park
Quincy, MA 02269-9101
NFPA 2001, Standard on Clean Agent Fire Extinguishant Systems

FM Approvals
1151 Boston Providence Turnpike
Norwood, MA 02062

United States Coast Guard
2100 Second Street SW
Washington, DC 20593-0001

RINA
10 Upper Belgrave Street
London, SW1X 8BQ

WARNING:

1. NEVER INSTALL A FIREBOY SYSTEM ON AN ACCESS DOOR THAT MAY OPEN OR SEPARATE IN AN EXPLOSION.
2. NEVER INSTALL THE ACTUATOR OF A FIREBOY SYSTEM IN CLOSE PROXIMITY TO SOURCES OF HIGH HEAT. RADIATED HEAT MAY CAUSE PREMATURE ACTUATION.
3. NEVER INSTALL THE MODELS LISTED IN THIS MANUAL HORIZONTALLY OR UPSIDE DOWN.
4. NEVER INSTALL A FIREBOY SYSTEM WHERE IT WILL TRAP OR BE IN DIRECT CONTACT WITH WATER.
5. NEVER INSTALL A FIREBOY UNIT IN A SPACE LARGER THAN ITS VOLUME RATING.
6. THIS DEVICE SHALL NOT BE INSTALLED OR USED IN AIRCRAFT AND/OR RACING VEHICLES.
7. FIREBOY SYSTEMS ARE NOT, NOR ARE THEY INTENDED TO BE, EXPLOSION SUPPRESSION DEVICES. THEY DO NOT LESSEN THE NEED TO INSPECT FOR FIRE HAZARDS AND TO VENTILATE ANY AREA WHERE FLAMMABLE FUMES MAY ACCUMULATE.
8. IN CASE OF ACCIDENTAL DISCHARGE, EVACUATE PROTECTED SPACE AND VENTILATE. DO NOT RETURN TO AREA UNTIL SPACE IS CLEAR OF AGENT. REFER TO HEALTH AND SAFETY SECTION (PAGE 16).

CAUTION:

ONLY COMPATIBLE FM APPROVED DETECTION AND ACTUATION EQUIPMENT MAY BE USED WITH THESE EXTINGUISHERS.

Specifications

MAEXXXNVC-BXXXX series extinguishers discharge automatically at specific temperatures, see below. MAE series extinguishers may be discharged manually at any temperature. All models introduce an atmospheric concentration of 5.85% into the protected space. This concentration includes a 30% safety factor to the 4.5% Minimum Extinguishing Concentration (MEC). Operational temperature range of extinguishers is 32°F (0°C) to 130°F (54°C).

Model Number	Volume Protected		Diameter		Total Height		Agent Weight		Shipping Weight		System Pressure (@70° F)
	ft ³	m ³	in	mm	in	mm	lbs	kgs	lbs	kgs	psi
MAE0025NVC-BXXXX	25	0.7	3.3	85	15.0	381	1.3	0.6	6	2.7	360
MAE0050NVC-BXXXX	50	1.4	3.3	85	18.7	476	2.7	1.2	10	4.5	360
MAE0075NVC-BXXXX	75	2.1	4.3	110	21.0	535	4.0	1.8	15	6.8	360
MAE0100NVC-BXXXX	100	2.8	4.3	110	21.0	535	5.4	2.4	16	7.3	360
MAE0125NVC-BXXXX	125	3.5	5.1	130	22.7	577	6.7	3.0	20	9.1	360
MAE0150NVC-BXXXX	150	4.3	5.1	130	22.7	577	8.1	3.7	25	11.3	360
MAE0175NVC-BXXXX	175	4.9	6.3	160	22.8	579	9.4	4.3	27	12.2	360
MAE0200NVC-BXXXX	200	5.7	6.3	160	22.8	579	10.7	4.9	29	13.2	360
MAE0225NVC-BXXXX	225	6.4	6.3	160	22.8	579	12.1	5.5	33	15.0	360
MAE0250NVC-BXXXX	250	7.0	6.3	160	22.8	579	13.4	6.1	34	15.4	360
MAE0275NVC-BXXXX	275	7.8	7.1	180	22.5	571	14.8	6.7	38	17.2	360
MAE0300NVC-BXXXX	300	8.5	7.1	180	22.5	571	16.1	7.3	39	17.7	360
MAE0325NVC-BXXXX	325	9.2	7.1	180	24.8	630	17.5	7.9	44	20.0	360
MAE0350NVC-BXXXX	350	10.0	7.1	180	24.8	630	18.8	8.5	45	20.4	360
MAE0375NVC-BXXXX	375	10.6	7.1	180	24.8	630	20.1	9.1	47	21.3	360
MAE0400NVC-BXXXX	400	11.3	7.1	180	32.8	834	21.5	9.8	54	24.5	360
MAE0450NVC-BXXXX	450	12.7	7.1	180	32.8	834	24.2	11.0	57	25.9	360
MAE0500NVC-BXXXX	500	14.1	7.1	180	32.8	834	26.9	12.2	62	28.1	360
MAE0550NVC-BXXXX	550	15.6	7.1	180	32.8	834	29.6	13.4	64	29.0	360
MAE0600NVC-BXXXX	600	17.0	7.1	180	39.0	991	32.2	14.6	73	33.1	360
MAE0650NVC-BXXXX	650	18.4	7.1	180	39.0	991	34.9	15.8	77	34.9	360
MAE0700NVC-BXXXX	700	19.8	7.1	180	39.0	991	37.6	17.1	79	35.8	360
MAE0750NVC-BXXXX	750	21.2	7.1	180	39.0	991	40.3	18.3	85	38.6	360
MAE0800NVC-BXXXX	800	22.6	10.0	254	27.1	688	43.0	19.5	91	41.3	360
MAE0850NVC-BXXXX	850	24.0	10.0	254	27.1	688	45.7	20.7	94	42.6	360
MAE0900NVC-BXXXX	900	25.5	10.0	254	33.3	845	48.4	22.0	104	47.2	360
MAE0950NVC-BXXXX	950	26.9	10.0	254	33.3	845	51.0	23.1	108	49.0	360
MAE1000NVC-BXXXX	1000	28.3	10.0	254	33.3	845	53.7	24.4	110	49.9	360
MAE1050NVC-BXXXX	1050	29.7	10.0	254	33.3	845	56.4	25.6	114	51.7	360
MAE1100NVC-BXXXX	1100	31.1	10.0	254	33.3	845	59.1	26.8	117	53.1	360
MAE1150NVC-BXXXX	1150	33.0	10.0	254	33.3	845	61.8	28.0	126	57.2	360
MAE1200NVC-BXXXX	1200	34.0	10.0	254	33.3	845	64.5	29.3	130	59.0	360
MAE1250NVC-BXXXX	1250	35.4	10.0	254	38.0	966	67.2	30.5	131	59.4	360
MAE1300NVC-BXXXX	1300	36.8	10.0	254	38.0	966	69.8	31.7	135	61.2	360
MAE1350NVC-BXXXX	1350	38.2	10.0	254	38.0	966	72.5	32.9	138	62.6	360

Specifications Continued

Model Number	Volume Protected		Diameter		Total Height		Agent Weight		Shipping Weight		System Pressure (@70° F)
	ft ³	m ³	in	mm	in	mm	lbs	kgs	lbs	Kgs	psi
MAE1400NVC-BXXXX	1400	39.6	10.0	254	38.0	966	75.2	34.1	141	64.0	360
MAE1450NVC-BXXXX	1450	41.0	10.0	254	38.0	966	77.9	35.3	144	65.3	360
MAE1500NVC-BXXXX	1500	42.5	10.0	254	38.0	966	80.6	36.6	147	66.7	360
MAE1550NVC-BXXXX	1550	43.9	10.0	254	47.3	1201	83.3	37.8	154	69.9	360
MAE1600NVC-BXXXX	1600	45.3	10.0	254	47.3	1201	86.0	39.0	157	71.2	360
MAE1650NVC-BXXXX	1650	46.7	10.0	254	47.3	1201	88.7	40.2	160	72.6	360
MAE1700NVC-BXXXX	1700	48.1	10.0	254	47.3	1201	91.3	41.4	163	73.9	360
MAE1750NVC-BXXXX	1750	49.6	10.0	254	47.3	1201	94.0	42.6	167	75.8	360
MAE1800NVC-BXXXX	1800	51.0	10.0	254	47.3	1201	96.7	43.9	170	77.1	360
Low Profile Models											
MAE0600NVC-4BXXX	600	17.0	10.0	254	27.1	688	32.2	14.6	76	34.5	360
MAE0650NVC-4BXXX	650	18.4	10.0	254	27.1	688	34.9	15.8	78	35.4	360
MAE0700NVC-4BXXX	700	19.8	10.0	254	27.1	688	37.6	17.1	84	38.1	360
MAE0750NVC-4BXXX	750	21.2	10.0	254	27.1	688	40.3	18.3	89	40.4	360

MAEXXXNVC-B = 175°F (79°C) Actuation Temperature

MAEXXXNVC-4B = 175°F (79°C) Actuation Temperature, Low Profile

MAEXXXNVC-30B = 155°F (68°C) Actuation Temperature

MAEXXXNVC-304B = 155°F (68°C) Actuation Temperature, Low Profile

MAEXXXNVC-33B = 135°F (57°C) Actuation Temperature

MAEXXXNVC-334B = 135°F (57°C) Actuation Temperature, Low Profile

When specifications listed on the label differ from this manual, the information listed on the label is correct.

360psi = 2482kPa = 24.8Bar

Operation of Firebox Fire Extinguisher

Manual operation of MAEXXXNVC-BXXXX Systems

1. In case of fire, do not wait for automatic actuation.
2. Close all openings leading to the protected space.
3. Shutdown all forced ventilation devices and electrical systems.
4. Actuate the system by:
 - Press the “Manual Discharge” button on the dedicated Release Panel, or
 - Activate a Pull Station connected to the Release Panel, or
 - Removing the safety pin from the “FIRE” T-handle and pull firmly.

Automatic operation MAEXXXNVC-BXXXX systems

- Triggered by a Heat or Smoke Detector connected to the Release Panel, or
- MAEXXXNVC-BXXXX temperature actuated bulb.

CAUTION:

LOOK AWAY FROM EXTINGUISHER AND REMOVE HAND QUICKLY WHEN ACTUATING WITH FINGER LOOP (BACKUP MANUAL OPERATION).

Backup Manual operation of MAEXXXNVC-BXXXX systems

1. In case of fire, do not wait for automatic actuation.
2. Close all openings leading to the protected space.
3. Shutdown all forced ventilation devices and electrical systems.
4. Actuate the system by pulling the Finger Loop down firmly. Refer to illustration on Page 30.

Signs of actuation

1. A loud sound similar to small arms fire.
2. A loud sound of rushing air.
3. Release Panel Notification.

When actuation occurs

1. Immediately shutdown all powered ventilation, and electrical systems.
2. Extinguish all smoking materials.
3. Do not open the protected space.
4. The protected space may see an increase in pressure during discharge. Appropriate relief vents may be needed where structural integrity of protected space is in question.

After actuation

1. Before inspecting for damage, allow the agent to “soak” the protected space for at least 15 minutes and wait for hot metals or fuels to cool.
2. Have approved portable extinguishers in hand and ready for use.
3. Do not breathe fumes or vapors caused by the fire and/or suppression agent. They are hazardous and toxic. Refer to Health and Safety section (Page 16).
4. Forced ventilation will often be necessary. Care should be taken to readily dissipate hazardous atmospheres and not merely move them to another location. Consideration should be given to exhaust paths when opening or venting the enclosure after discharge. Ventilation should not be directed near any area that might be used as a gathering spot for personnel.

CAUTION:

IF A SUSPENDED CEILING EXISTS, IT IS ASSUMED THAT THE CLEAN AGENT DISCHARGE WILL NOT RESULT IN DISPLACEMENT OF THE CEILING TILES. INCREASED CONFIDENCE CAN BE OBTAINED IF CEILING TILES ARE CLIPPED WITHIN 4FT (1.2M) OF THE NOZZLE AND ALL PERIMETER TILES.

Before Installation

1. Check the system for damage during shipment.
2. Check the pressure gauge to be sure the gauge pointer lies within the green zone at 70°F (21°C).
3. The correct weight is shown on the label for the appropriate model.
4. Confirm the volume of the protected space in cubic feet or cubic meters by multiplying the width, by the length, by the height of the space; make no deductions for installed equipment.
5. Verify calculated volume with volume shown on label and model specifications section.

Selecting a Location

1. Do not install a Fireboy system rated for less cubic volume than the volume of the space to be protected.
2. The maximum approved distance from the cylinder nozzle to ceiling is 24in (610mm).
3. Orientation:
 - Mount extinguisher in vertical orientation only.
 - To prevent accelerated corrosion, do not mount directly to an aluminum/metal surface. Maintain galvanic isolation between the extinguisher and metal mounting surface.
 - Direct the actuator towards the opposite wall of the space.
4. The approved ceiling height of the protected space is as follows:
 - 2.0ft (0.7m) to 11.3ft (3.4m) with an automatic actuation temperature of 175°F (79°C).
 - 2.0ft (0.7m) to 16ft (4.9m) with an automatic actuation temperature of 155°F (68°C) or lower.
5. The maximum approved radial reach and area of coverage is 21.0ft (6.4m), 303ft² (28.1m²).

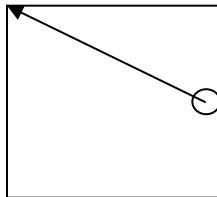

Mounting Fireboy system

DANGER:

ACCIDENTAL DISCHARGE DURING HANDLING OR INSTALLATION MAY CAUSE SERIOUS INJURY. DO NOT LIFT, CARRY, OR HANDLE BY VALVE, PRESSURE SWITCH, OR CABLE. WEAR EYE PROTECTION WHEN INSTALLING OR SERVICING CYLINDER. REFER TO HEALTH AND SAFETY SECTION (PAGE 16).

CAUTION:

PLYWOOD OR STARBOARD SUPPORT BACKER MAY BE REQUIRED TO MOUNT THE EXTINGUISHER TO THE FRAMING STUDS IN THE WALL.

Models 025-150

1. Use appropriate size and length bolts and lock washers to secure using all 4 mounting holes.
2. Mounting hardware can be installed with cylinder clamped in bracket.

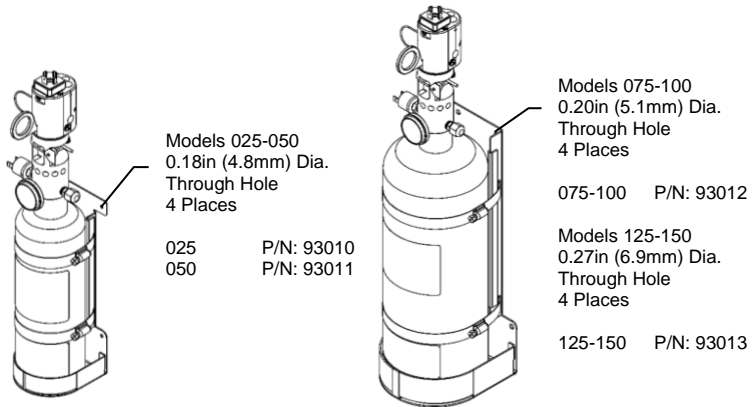

Models 175-550

1. Generously loosen cylinder clamps and remove cylinder.
2. Locate cylinder in safe and secure location to prevent cylinder from tipping.
3. Use appropriate size and length bolts and lock washers to secure bracket using all 6 mounting holes.
4. With bracket secured, place cylinder back in bracket and tighten cylinder clamps.

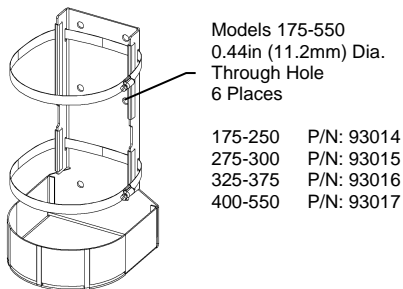

Mounting Fireboy system Continued

Models 600-1800

1. Use appropriate size and length bolts and lock washers to fasten to wall.
2. Mount the Shelf Brackets using the 6 mounting holes. Be sure to include unistrut while mounting bracket.
3. Locate upper bracket 1in (25.4mm) below the top weld seam of cylinder. Be sure to include spacer while mounting unistrut.
4. Install Clamps in unistrut and tighten with provided fasteners.
5. Models 1250-1800 will include a third clamp, to be located at the midpoint between the other two clamps.

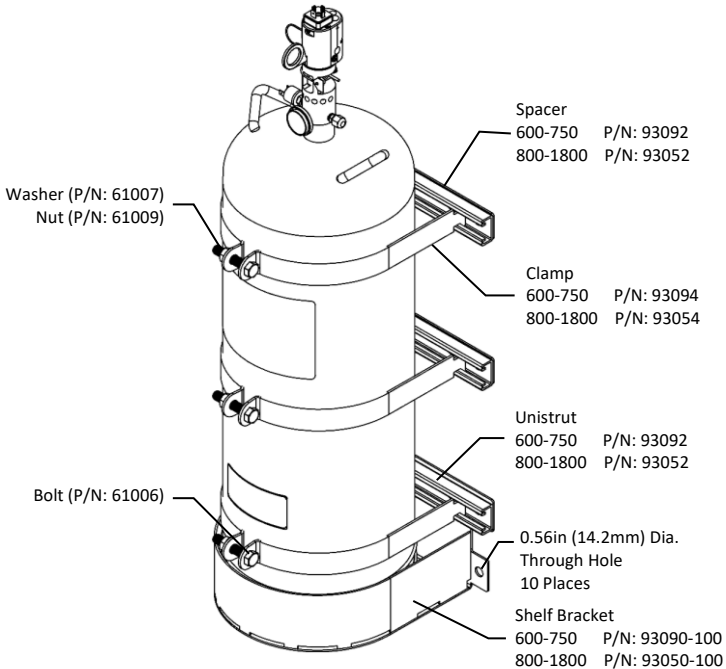

NOTE:

REFERENCE APPENDIX A IF INSTALLING OPTIONAL MANUAL PULL CABLE (P/N: E-4209-XXX, XXX = LENGTH IN FEET).

Electrical Connections to Release Panel

CAUTION:

ALL MODELS COVERED IN THIS MANUAL MUST BE INSTALLED WITH COMPATIBLE FM APPROVED SMOKE DETECTION AND ACTUATION EQUIPMENT.

CAUTION:

INSTALLATION SHALL BE DONE BY QUALIFIED PERSONNEL AUTHORIZED TO DO SO BY THE AUTHORITIES HAVING JURISDICTION FOR THE PARTICULAR APPLICATION IN WHICH THE PRODUCT IS BEING USED. ELECTRICAL WIRING SHALL BE IN ACCORDANCE WITH NATIONAL ELECTRICAL CODES. IMPROPER WIRING MAY RENDER THE UNIT INOPERABLE, DAMAGE COMPONENTS, OR CAUSE A FIRE, AND WILL VOID ALL WARRANTIES.

NOTE:

FOLLOW THE INSTRUCTIONS FOR INSTALLING THE RELEASE PANEL AND ITS COMPONENTS LISTED IN THE MANUAL PROVIDED WITH THESE COMPONENTS.

NOTE:

DISCONNECT POWER TO THE RELEASE PANEL BEFORE PROCEEDING TO AVOID UNNECESSARY TROUBLE ALARMS ON THE RELEASE PANEL.

A wire harness is provided for both the Pressure Switch (P/N: 21360) and Electric Actuation (P/N: 21359) connections. Connections to the wire harnesses should be made inside of a junction box.

Pressure Switch

1. Feed a 14-18 AWG 2-Conductor cable to a junction box located mounted within 24in (610mm) of the Extinguisher for wire connections.
2. Connect the "Low P Switch +" terminal from the Release Panel to one of the leads of the MAE Pressure Switch Harness. Pressure Switch is not Polarity Sensitive.
3. Connect the "Low P Switch +" terminal from the Release Panel to the remaining lead of the MAE Pressure Switch Harness.
4. Connect the Female Spade Terminals of the Pressure Switch Harness to the Male Spades on the Fireboy MAE Extinguisher Pressure Switch.

NOTE:

RELEASE PANEL MAY REQUIRE END-OF-LINE RESISTOR ON LOW-PRESSURE CIRCUIT. PLACE THE END-OF-LINE RESISTOR FROM THE PANEL IN-LINE WITH THE WIRE CONNECTING TO THE "LOW P SWITCH -" TERMINAL OF THE RELEASE PANEL.

Electric Release Actuator

1. Remove the screw in the Female DIN connector and disconnect the Female DIN connector from the Male DIN connector.
2. Feed a 14-18 AWG 2-Conductor cable to a junction box located mounted within 24in (610mm) of the Extinguisher for wire connections.
3. Connect the "Exting. +" terminal from the Release Panel to one of the leads of the MAE Actuation Harness. Actuator is not Polarity Sensitive.
4. Connect the "Exting. -" terminal from the Release Panel to the remaining lead of the MAE Actuation Switch Harness.
5. Remove the inner portion of the DIN connector re-insert it in desired orientation.
6. Connect the Female DIN connector of the Harness to the Male DIN connector located on the top of the MAE Extinguisher Valve.
7. Re-insert screw into the Female DIN connector and secure it to the Male DIN connector.

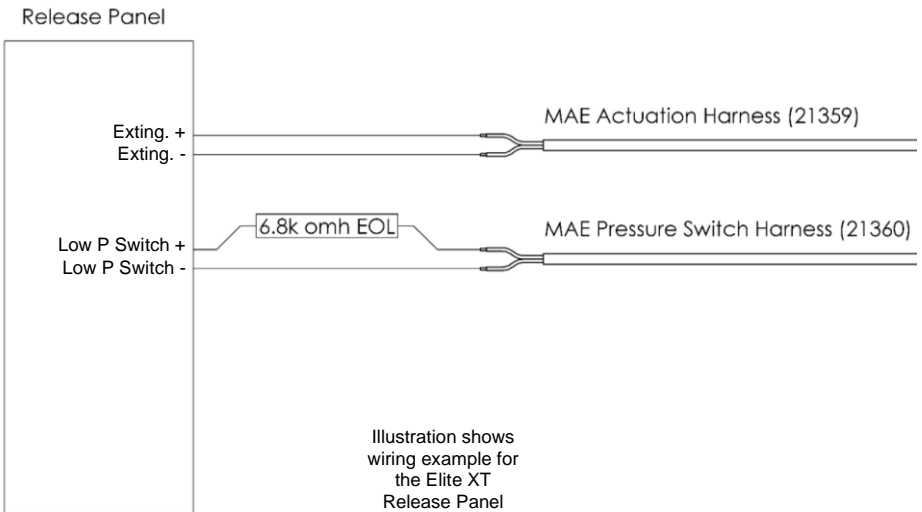

Arming the Fireboy MAE Fire Extinguisher

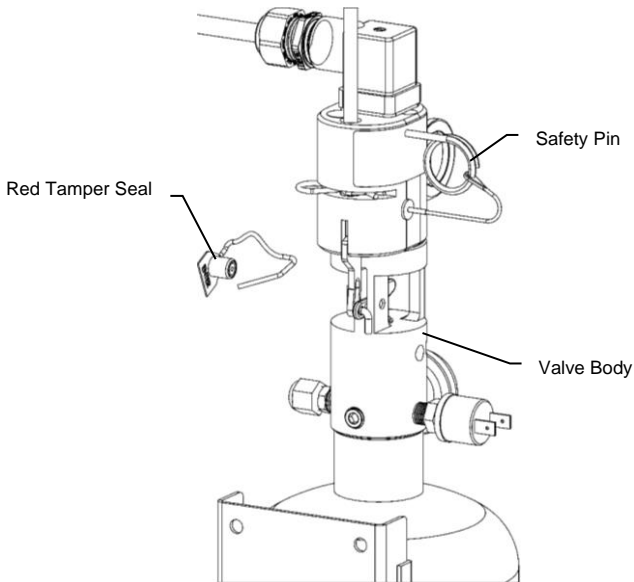

With T-Handle previously secured, remove Red Tamper Seal from Extinguisher to remove Safety Pin and store in provided hole. System is now operational.

NOTE:

FOLLOW THE INSTRUCTIONS FOR POWERING THE RELEASE PANEL AND ITS COMPONENTS LISTED IN THE MANUAL PROVIDED WITH THESE COMPONENTS.

RELEASE PANEL WILL MONITOR PRESSURE SWITCH, ELECTRIC RELEASE ACTUATOR, AND SAFETY PIN. FOLLOW INSTRUCTIONS IN THE RELEASE PANEL'S MANUAL IF TROUBLESHOOTING IS NECESSARY.

INSTALLATION CHECKLIST	
Verified Volume of Protected Space	
Verified Extinguisher Model is for Volume of Protected Space	
Mounted Extinguisher according to installation instructions	
Located extinguisher according to installation instructions	
Orientated extinguisher according to installation instructions	
Nozzle is no greater than 24in (610mm) from ceiling	
Secured Bracket according to installation instructions	
Installed Release Panel according to Release Panel Manual	
Connected Additional Equipment and Detectors	
Connected Fireboy MAE Extinguisher Pressure Switch	
Connected Fireboy MAE Extinguisher Electric Release Actuator	
Removed Safety Pin and placed in the Storage Hole on Extinguisher (System is operational)	
Powered Release Panel	
Review Maintenance of system	
Review Health and Safety Section of manual	
OPTIONAL	
Installed Cable According to installation instructions	
Located Manual Release Handle according to installation instructions	
Routed Cable according to installation instructions	
No more than Sixteen 90° Bends (16 x 90° = 1440°)	
Secured Cable according to installation instructions	
Installed Manual Release Handle according to installation instructions	
Connected Cable to Extinguisher according to installation instructions	

Maintaining Fireboy Fire Extinguisher

1. Inspect the pressure gauge and the system daily. Pointer must indicate in green zone at 70°F (21°C).
2. Compare actuator to illustration below to determine if the extinguisher is charged or discharged.

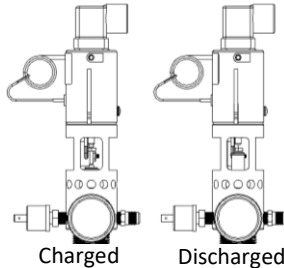

3. Remove and weigh the complete unit (without brackets) on a certified scale every six (6) months and record on tag provided.

NOTE:

REFERENCE APPENDIX B FOR DISCONNECTION INSTRUCTIONS IF OPTIONAL MANUAL PULL CABLE (P/N: E-4209-XXX, XXX = LENGTH IN FEET) IS INSTALLED.

4. Remove fire extinguisher from service immediately for repair or replacement if measured gross weight is greater than 5% below what is stated on unit's label (Label Gross Weight x 0.95 = Minimum Allowable Weight).
5. Inspect cylinder in accordance with CGA C-6, every 5 years OR have cylinder hydrostatic tested every 12 years.

Maintaining the Extinguisher Releasing Circuit

If the "Releasing Trouble" LED turns ON at the Release Panel;

1. Verify that the Safety Pin is fully installed in the storage position on the Valve.
2. With the Safety Pin in the storage position, use a continuity tester to check the Electric Actuator on the system bottle itself:
 - Disconnect and remove the DIN connector located at the top of the Extinguisher Valve and place the probes of the continuity tester directly on the spade connectors marked as 1 & 2.
 - A closed circuit indicates a functioning Electric Actuator.
3. Check the continuity of the remaining wiring circuit.
4. Should the continuity of the Electric Actuator indicate an open circuit, the system will have to be returned to the factory for either replacement or repair, depending upon the model involved.

Health and Safety

- A properly designed and installed suppression system should not present any significant health or safety problems; however, there are basic precautions to be taken to avoid accidents, and aspects of the system operation that should be fully understood.
- 3M Novec 1230 extinguishes fires by causing a cooling effect and by causing a chemical reaction with the combustion products and not by displacement of oxygen as is the extinguishment method of carbon dioxide. The agent therefore provides the ability to utilize the 3M Novec 1230 system in occupied areas.
- 3M Novec 1230 can decompose at high temperatures to form halogen acids. If so, their presence is readily detected as a sharp, pungent odor long before hazardous maximum exposure levels are reached.
- The noise created by the 3M Novec 1230 agent discharging can be loud enough to startle people in the vicinity but is unlikely to cause any permanent injury. Turbulence caused by high velocity discharge can dislodge substantial objects directly in its path and cause enough general turbulence within the protected area to move paper and light objects.
- Direct contact with the vaporizing liquid discharged from a 3M Novec 1230 nozzle has a cooling effect on objects and in extreme cases can cause frostbite to the skin. The liquid phase vaporizes rapidly when mixed with air and therefore limits the risk to the immediate vicinity of the nozzle. Reduction in visibility will occur due to the condensation of water vapor.

WARNING:

THE DISCHARGE OF CLEAN AGENT SYSTEMS TO EXTINGUISH A FIRE CAN RESULT IN A POTENTIAL HAZARD TO PERSONNEL FROM THE NATURAL FORM OF THE CLEAN AGENT OR FROM THE PRODUCTS OF COMBUSTION THAT RESULTS FROM EXPOSURE OF THE AGENT TO THE FIRE OR HOT SURFACES. TO AVOID SERIOUS PERSONAL INJURY, UNNECESSARY EXPOSURE OF PERSONNEL TO THESE POTENTIAL HAZARDS MUST BE AVOIDED.

WARNING:

HMS: 0-0-1/DODECAFLUORO-2-METHYLPENTAN-3-ONE/CONTENTS UNDER PRESSURE. 0-0-0/NITROGEN EXPELLANT GAS/VERY COLD, CONTENTS UNDER PRESSURE. CONSULT 3M ELECTRONICS MARKETS MATERIALS DIVISION, 3M CENTER, ST. PAUL, MN 55144-1000; EMERGENCY PHONE: 1-800-364-3577.

First Aid

- Skin** Maintain at body temperature, thaw affected area with gentle heat. If frostbite occurs, seek medical assistance. Do not rub affected area.
- Eyes** Apply gentle heat. Do not allow patient to touch affected area, seek medical assistance.

For more information on 3M Novec 1230, please see the SDS (Page 18).

DANGER:

1. DO NOT HANDLE BY ACTUATOR
2. DO NOT DROP
3. KEEP AWAY FROM CHILDREN
4. KEEP AWAY FROM EXTREME HEAT
5. DO NOT DISCHARGE ANY FIREBOY AUTOMATIC OR MANUAL/AUTOMATIC SYSTEM UNLESS SECURELY FASTENED IN ACCORDANCE WITH THE OWNER'S MANUAL
6. NEVER ATTEMPT TO DISASSEMBLE ANY COMPONENT OF THIS SYSTEM
7. ALWAYS WEAR EYE, FACE AND BODY PROTECTION WHEN INSTALLING, REMOVING OR WORKING IN THE IMMEDIATE VICINITY OF THIS SYSTEM

Principle health hazards

- Death without warning if high concentrations are inhaled
- Reduced oxygen available for breathing
- Frostbite from direct exposure
- Increased susceptibility to the toxicity of excess exposure for individuals with pre-existing diseases of the central nervous system, cardiovascular system, lungs or kidneys
- Toxic by-products are produced when this agent extinguishes fire

Medical instructions

- If high concentrations are inhaled, immediately move the exposed to fresh air and keep calm
- If not breathing, give artificial respiration. Seek medical assistance
- If breathing is difficult give oxygen. Seek medical assistance
- In case of skin contact immediately flush skin with water for 15 minutes
- Treat for frostbite if necessary by gently warming affected area. Seek medical assistance if irritation is present
- In case of eye contact, immediately flush eyes with plenty of water for at least 15 minutes. Seek medical assistance
- Wash contaminated clothing before reuse

Safety Data Sheet

SECTION 1. IDENTIFICATION

Product identifier: 3M™ Novec™ 1230 [FK-5-1-12] (Fire extinguishing agent)
Product identification numbers: 98-0212-3203-2, 98-0212-3217-2, 98-0212-3414-5
Intended Use: Streaming and flooding fire extinguishing agent

Manufacturer/Supplier: Fireboy-Xintex LLC Fireboy-Xintex UK Operations Limited
O-379 Lake Michigan Dr. Unit 10 Holton,
Grand Rapids, MI 49534 Holton Heath Trading Park
1-616-735-9380 Poole Dorset BH16 6LT UK
44 (0) 845 389 9462

SECTION 2. HAZARDS IDENTIFICATION

OSHA/HCS status: This material is considered hazardous by OSHA Hazard Communication Standard (29 CFR 1910.1200)

Classification of substance or mixture: Gases under Pressure

GHS label elements:

Hazard Pictograms:



Signal word: Warning

Hazard statements: H280: Contains gas under pressure; may explode if heated
P210: Keep away from heat/spark/open flame. – No smoking
P233: Keep container tightly closed in a cool/well-ventilated place
P260: Do not breathe dust/fumes/gas/vapors/spray
P273: Avoid release to the environment
P280: Wear protective gloves/protective clothing/eye protection/face protection
P403: Use and store only in a well-ventilated area
Other Hazards: May cause frostbite
May displace oxygen and cause rapid suffocation
Overheating and over pressurizing may cause gas release or violent cylinder bursting

SECTION 3. COMPOSITION/INFORMATION ON INGREDIENTS

Component	CAS-No.	Concentration
1,1,1,2,2,4,5,5-Nonafluoro-4-(trifluoromethyl)-3-pentanone	756-13-8	99.5%

SECTION 4: FIRST AID MEASURES

- Inhalation: Remove person to fresh air. If you are concerned, get medical advice.
- Skin Contact: Wash with soap and water. If signs/symptoms develop, get medical attention.
- Eye Contact: Flush with large amounts of water. Remove contact lenses if easy to do. Continue rinsing. If signs/symptoms persist, get medical attention.
- If Swallowed: Rinse mouth. If you feel unwell, get medical attention.

SECTION 5. FIRE FIGHTING MEASURES

Suitable extinguishing media: Product is a fire-extinguishing agent. Material will not burn. Use a fire fighting agent suitable for the surrounding fire.

Special hazards arising from the substance or mixture: Exposure to extreme heat can give rise to thermal decomposition.

Hazardous Decomposition or By-Products:

<u>Substance</u>	<u>Condition</u>
Carbon monoxide	During Combustion
Carbon dioxide	During Combustion
Hydrogen Fluoride	During Combustion
Toxic Vapor, Gas, Particulate	During Combustion

Special protective actions for fire-fighters: When firefighting conditions are severe and total thermal decomposition of the product is possible, wear full protective clothing, including helmet, self-contained, positive pressure or pressure demand breathing apparatus, bunker coat and pants, bands around arms, waist and legs, face mask, and protective covering for exposed areas of the head.

SECTION 6. ACCIDENTAL RELEASE MEASURES

Personal precautions, protective equipment and emergency procedures: Evacuate area.

Ventilate the area with fresh air. For large spill, or spills in confined spaces, provide mechanical ventilation to disperse or exhaust vapors, in accordance with good industrial hygiene practice.

Refer to other sections of this SDS for information regarding physical and health hazards, respiratory protection, ventilation, and personal protective equipment.

Environmental precautions: Avoid release to the environment. For larger spills, cover drains and build dikes to prevent entry into sewer systems or bodies of water.

Methods and material for containment and cleaning up: Contain spill. Working from around the edges of the spill inward, cover with bentonite, vermiculite, or commercially available inorganic absorbent material. Mix in sufficient absorbent until it appears dry. Remember, adding an absorbent material does not remove a physical, health, or environmental hazard. Collect as much of the spilled material as possible. Place in a closed container approved for transportation by appropriate authorities. Seal the container. Dispose of collected material as soon as possible.

SECTION 7. HANDLING AND STORAGE

Handling: For industrial or professional use only. Contents may be under pressure, open carefully. Do not breathe thermal decomposition products. Do not eat, drink or smoke when using this product. Wash thoroughly after handling. Avoid release to the environment.

Storage: Protect from sunlight. Do not store in temperature above 130°F (54°C). Store away from strong bases. Store away from amines.

SECTION 8. EXPOSURE CONTROLS/PERSONAL PROTECTION

Engineering controls: Provide appropriate local exhaust when product is heated. For those situations where the material might be exposed to extreme overheating due to misuse or equipment failure, use with appropriate local exhaust ventilation sufficient to maintain levels of thermal decomposition products below their exposure guidelines. Use general dilution ventilation and/or local exhaust ventilation to control airborne exposures to below relevant Exposure Limits and/or control dust/fume/gas/mist/vapors/spray. If ventilation is not adequate, use respiratory protection equipment.

Eye/face protection: Eye protection not required.

Skin/hand protection: No protective gloves required

Respiratory protection: Use a positive pressure supplied-air respirator if there is a potential for over exposure from an uncontrolled release, exposure levels are not known, or under any other circumstances where air-purifying respirators may not provide adequate protection. If thermal degradation products are expected, use a full-face piece supplied-air respirator.

Exposure limits: Not established.

SECTION 9. PHYSICAL AND CHEMICAL PROPERTIES

Specific Physical Form:	Liquid
Odor, Color, Grade:	Clear, colorless, low odor.
General Physical Form:	Liquid
Auto ignition temperature:	<i>Not Applicable</i>
Flash Point:	No flash point
Flammable Limits (LEL):	None detected
Flammable Limits (UEL):	None detected
Boiling Point:	49°C [@ 760 mmHg]
Vapor Density:	11.6 [<i>Ref Std: AIR=1</i>]
Vapor Pressure:	40.4kPa [@ 25 °C]
Specific Gravity:	1.6 [<i>Ref Std: WATER=1</i>]
pH:	<i>Not Applicable</i>
Melting point:	-108°C
Solubility in Water:	Nil
Evaporation rate:	> 1 [<i>Ref Std: BUOAC=1</i>]
Volatile Organic Compounds:	1600g/l [<i>Test Method: calculated SCAQMD rule 443.1</i>]
Kow - Oct/Water partition coef:	<i>Not Applicable</i>
Percent volatile:	100%
VOC less H2O & Exempt Solvents:	1600g/l [<i>Test Method: calculated SCAQMD rule 443.1</i>]
Viscosity:	0.6 centipoise [@ 25°C]

SECTION 10. STABILITY AND REACTIVITY

Chemical stability:	Stable
Conditions to avoid:	Light
Materials to avoid:	Strong bases, Amines, Alcohols
Hazardous Polymerization:	Hazardous polymerization will not occur.

Hazardous Decomposition or By-Products:

<u>Substance</u>	<u>Condition</u>
Carbon monoxide	During Combustion
Carbon dioxide	During Combustion
Hydrogen Fluoride	During Combustion
Toxic Vapor, Gas, Particulate	During Combustion

SECTION 11. TOXICOLOGICAL INFORMATION

Please contact the address listed on the first page of the SDS for Toxicological Information on this material and/or its components.

SECTION 12. ECOLOGICAL INFORMATION

<u>Test Organism</u>	<u>Test Type</u>	<u>Result</u>
Green algae, Selenastrum capricornutum	72 hrs Effect Conc. 50%	7.7mg/l
Zebra Fish, Brachydanio rerio	96 hrs Lethal Conc. 50%	>1200mg/l
Water flea, Daphnia magna	48 hours Effect Concentration 50%	>1200mg/l
Green algae, Selenastrum capricornutum	72 hours No obs Effect Conc	1.2mg/l

Please contact the address listed on the first page of the SDS for additional ecotoxicological information on this material and/or its components.

Chemical fate information: Not determined

Photolytic half-life: 3-5 days

Photolytic degradation products may include Trifluoroacetic acid (TFA)

NOTE: Hydrolysis is not expected to be a significant degradation pathway. Product is highly insoluble in water and volatile and use as a clean extinguishing agent would not typically result in releases to aquatic environments.

SECTION 13. DISPOSAL CONSIDERATIONS

Dispose of contents/container in accordance with the local/regional/national/international regulations.

Dispose of waste product in a permitted industrial waste facility. As a disposal alternative, incinerate in a permitted waste incineration facility. Proper destruction may require the use of additional fuel during incineration processes. Combustion products will include HF. Facility must be capable of handling halogenated materials. Empty drums/barrels/containers used for transporting and handling hazardous chemicals (chemical substances/mixtures/preparations classified as Hazardous as per applicable regulations) shall be considered, stored, treated & disposed of as hazardous wastes unless otherwise defined by applicable waste regulations. Consult with the respective regulating authorities to determine the available treatment and disposal facilities.

EPA Hazardous Waste Number (RCRA): Not regulated

SECTION 14. TRANSPORT INFORMATION

ID Number(s): 98-0212-3031-7, 98-0212-3201-6, 98-0212-3203-2, 98-0212-3217-2, 98-0212-3371-7, 98-0212-3414-5, 98-0212-3588-6

3M Novec 1230 by itself is not regulated by DOT

Or – If packaged as a charged Fire Extinguisher...

DOT	UN number:	1044
	Proper shipping name:	Fire Extinguishers
	Class:	2.2 (Non-Flammable Gas)
	Labelling No.:	2.2
IATA_C	UN number:	1044
	Proper shipping name:	Fire Extinguishers
	Class:	2.2 (Non-Flammable Gas)
	Labelling No.:	2.2
IMDG	UN number:	1044
	Proper shipping name:	Fire Extinguishers
	Class:	2.2 (Non-Flammable Gas)
Labelling No.:		2.2

SECTION 15. REGULATORY INFORMATION

US federal regulations: Contact Fireboy-Xintex LLC for more information.

311/312 Hazard Categories: Fire Hazard – No Pressure Hazard – No,
 Reactivity Hazard – No Immediate Hazard – No
 Delayed Hazard - No

State regulations: Contact Fireboy-Xintex LLC for more information.

Chemical inventories:

The components of this product are in compliance with the new substance notification requirements of CEPA.

The components of this material are in compliance with the China "Measures on Environmental Management of New Chemical Substance". Certain restrictions may apply. Contact the selling division for additional information.

The components of this material are in compliance with the provisions of the Korean Toxic Chemical Control Law. Certain restrictions may apply. Contact the selling division for additional information.

The components of this material are in compliance with the provisions of Japan Chemical Substance Control Law. Certain restrictions may apply. Contact the selling division for additional information.

The components of this material are in compliance with the provisions of Philippines RA 6969 requirements. Certain restrictions may apply. Contact the selling division for additional information.

The components of this product are in compliance with the chemical notification requirements of TSCA.

Contact Fireboy-Xintex LLC for more information.

International regulations: Contact Fireboy-Xintex LLC for more information.

Additional information: U.S. EPA. Significant New Alternatives Policy Program (SNAP) approved for uses is streaming and flooding fire protection application. This SDS has been prepared to meet the U.S. OSHA Hazard Communication Standard, 29 CFR 1910.1200.

SECTION 16. OTHER INFORMATION

NFPA Hazard Classification:

Health: 3 Flammability: 0 Reactivity: 1 Special Hazards: None

National Fire Protection Association (NFPA) hazard ratings are designed for use by emergency response personnel to address the hazards that are presented by short-term, acute exposure to a material under conditions of fire, spill, or similar emergencies. Hazard ratings are primarily based on the inherent physical and toxic properties of the material but also include the toxic properties of combustion or decomposition products that are known to be generated in significant quantities.

HMIS Hazard Classification:

Health: 0 Flammability: 0 Reactivity: 1 Protection: X - See PPE section

The information provided in this Safety Data Sheet is correct to the best of our knowledge, information and belief at the date of its publication. The information given is designed only as a guidance for safe handling, use, processing, storage, transportation, disposal and release and is not to be considered a warranty or quality specification. The information relates only to the specific material designated and may not be valid for such material used in combination with any other materials or in any process, unless specified in the text.

Revision: May 6, 2016

January 27, 2017

April 27, 2018

Returning Fireboy-Xintex Equipment

No product may be returned for credit or repair without a written "Returned Material Authorization" (RMA) form. Purchaser must call or email Fireboy-Xintex 616-735-9380 or fireboy@fireboy-xintex.com for an RMA. For international customers, call or email Fireboy-Xintex UK Operations Limited +44 (0) 845 389 9462 or fireboyeu@fireboy-xintex.com. If due to extenuating circumstances a product is to be returned, after approval it must be received in 100% new/resalable condition. Products stored by the buyer for more than 26 weeks may not be returned for any reason. Maintaining fresh and current inventory is the responsibility of the buyer.

Recharging Fireboy Extinguishers

Fireboy-Xintex cylinders comply with DOT specification 4B/240, 4B/360, and 4BW/360 which allows for recharging as long as the extinguisher was not discharged due to a fire and passes visual inspection in accordance with CGA C-6, or a hydrostatic test. Extinguisher cannot be recharged or refilled in the field. Contact manufacturer for details on the recharging process.

3 Year Limited Warranty

This Warranty is in lieu of all other expressed or implied Warranties

Seller warrants title, materials, and workmanship on equipment, except components manufactured by others for which the Seller assigns, as permitted, the original manufacturer's warranty. Seller's warranty shall be for a period of (3) three years from the date of sale to the ORIGINAL CONSUMER PURCHASER, during which non-conforming equipment returned to the Seller at Buyer's expense and risk, be repaired or replaced at the Seller's option. Fireboy-Xintex will repair or replace products found to be defective in materials or workmanship within the period set forth above, provided that: (a) the product has not been subjected to abuse, contamination, neglect, accident, incorrect wiring not our own, improper installation or servicing, or used in violation of instructions furnished by Fireboy-Xintex and (b) as to any prior defects in materials or workmanship covered by this warranty, the product has not been repaired or altered by anyone except Fireboy-Xintex and (c) the serial number has not been removed, defaced or otherwise changed, and (d) examination discloses, in the judgment of Fireboy-Xintex, does not assume the costs of removal and/or installation of the product or any other incidental costs of removal and/or installation of the product or any other incidental costs which may arise as a result of any defect in material or workmanship, and (e) upon discovery of defect, Buyer shall immediately cease use of and notify Fireboy-Xintex.

Any warranty implied by law, including warranties of merchantability or fitness, is in effect only for the duration of the expressed warranties set forth above, no person is authorized to give any other warranty, or to assume for Fireboy-Xintex any other liability in connection with the sale of its products; Fireboy-Xintex shall not be liable for the loss of use, revenue, or profit or for any injury, or for any other consequential or incidental damages, buyer is not relying on seller's judgment regarding his or her particular requirements, and has had an opportunity to inspect the product to his or her satisfaction.

This warranty gives you specific legal rights, and you may also have other rights, which vary, from location to location.

Contact information listed below. For US customers, contact Fireboy-Xintex LLC. For international customers, contact Fireboy-Xintex UK Operations Limited.

www.fireboy-xintex.com

Fireboy-Xintex LLC
O-379 Lake Michigan Dr. NW
Grand Rapids, MI 49534
fireboy@fireboy-xintex.com
Phone (616) 735 9380

Fireboy-Xintex UK Operations Limited
10 Holton Road, Holton Heath Trading Park
Poole Dorset BH16 6LT UK
fireboyeu@fireboy-xintex.com
Phone +44 (0) 845 389 9462

WARNING:

1. ALL FIREBOY MAE SYSTEM INSTALLATIONS MUST USE ONLY GENUINE FIREBOY CABLES AND ASSOCIATED COMPONENTS THAT ARE ENGINEERED SPECIFICALLY FOR THIS APPLICATION. NOTHING ELSE WILL PROVIDE THE INTENDED DEGREE OF SAFETY AND RELIABILITY INHERENT IN THESE SYSTEMS.
2. ANY SUBSTITUTION WILL VOID ALL LABORATORY APPROVALS AND FIREBOY-XINTEX WARRANTIES, AND MAY RESULT IN AN INOPERATIVE SYSTEM, AND UNSAFE AND HAZARDOUS CONDITIONS.
3. NEVER INSTALL A MANUAL RELEASE HANDLE IN THE SPACE TO BE PROTECTED.

CAUTION:

DO NOT CONNECT CABLE TO CYLINDER AT THIS TIME!

Routing the Cable

1. Locate the legend plate (1.9in (48mm) x 3.6in (92mm) with 7/16in (11.1mm) hole) for the manual release handle.
 - On a solid and secure surface (Minimum of 1/4in (6.4mm) thick)
 - In full view of the operator
 - With enough clearance for the cable ferrule to extend approximately 12in (304.8mm) behind the panel
 - Angle Adaptor CAA-0285-01 available where clearance is limited
2. Using the legend plate as a template, locate and drill a 13/32in (10.3mm) hole.
3. Route the cable in the most direct manner, with as few bends as possible, to the cylinder location.
 - Do not bend in a radius of less than 6in (152.4mm) (a 12in (304.8mm) circle)
 - Follow the same route as manufacturer installed cables, if possible (Example: Steering, throttle, and transmission cables)
 - Do not subject cable to pinching or crushing, rubbing, extreme vibration, sharp bending or kinking, or extremes of heat or cold
 - Do not exceed 1440° of total bends (Example: 16 bends x 90° = 1440°)
 - Use the shortest allowable cable whenever possible
 - Maximum manual cable length is 100ft (30.5m)
4. Secure loose sections of the cable with the included nylon clamps.
 - Do not clamp cable in a bend
 - Do not crush cable with clamps

Legend Plate and T-Handle

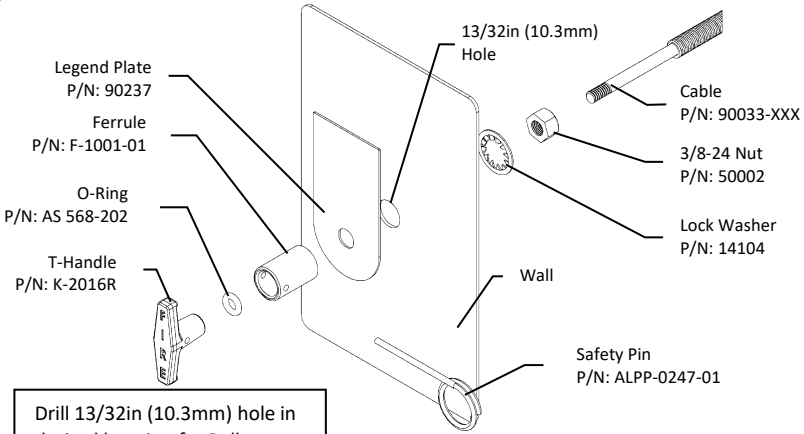

Drill 13/32in (10.3mm) hole in desired location for Pull Station.

Peel off paper and press legend plate firmly in place. Install 3/8-24 Nut and Lock Washer on Cable and position through hole. Leave enough space to tighten later.

NOTE: Temperature must be above +50°F (10°C) for proper adhesion.

Note: Do NOT thread further than Ferrule's internal threads.

Thread Ferrule onto Cable using 3 full revolutions. Adjust Ferrule so that holes are parallel to the floor and tighten Nut.

Legend Plate and T-Handle Continued

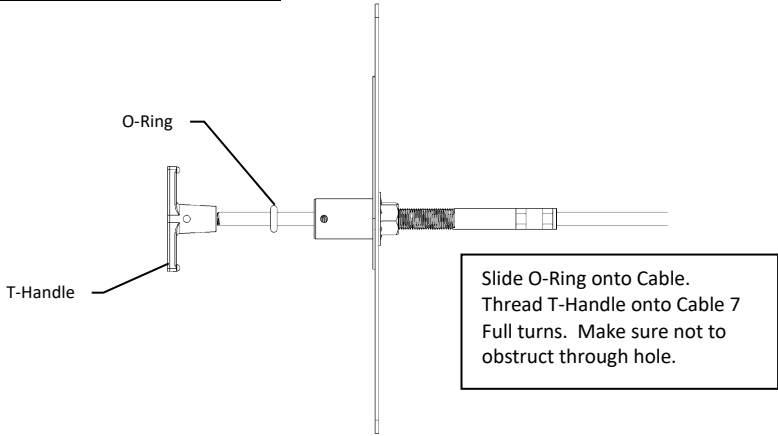

With Cable **DISCONNECTED** from extinguisher, take this time to test Cable operation. Cable should slide freely.

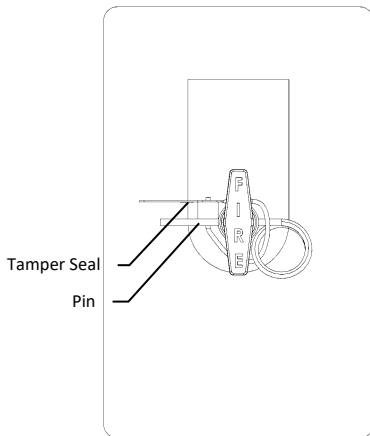
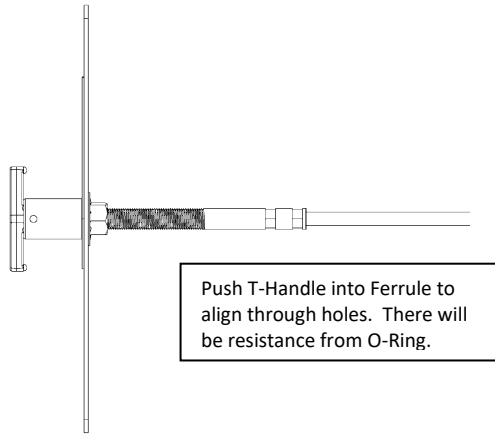

Connecting Cable to Cylinder

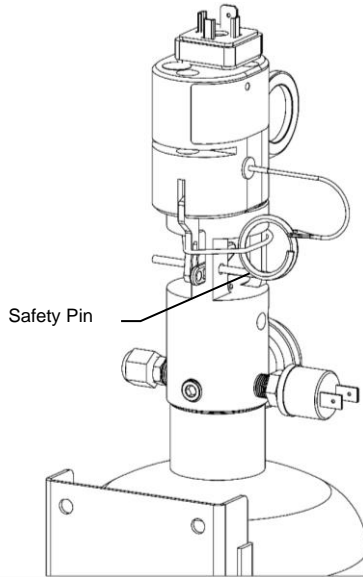

Extinguisher should be securely mounted and Cable should be routed.
Be sure the Safety Pin is in place.

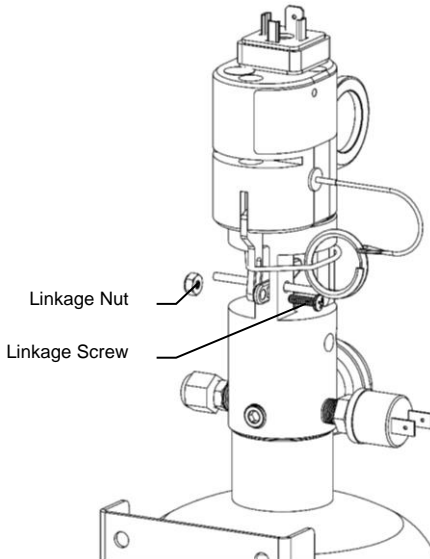

Carefully remove the Linkage Nut and Linkage Screw connecting the
Actuation Linkage to the Actuation Lever.

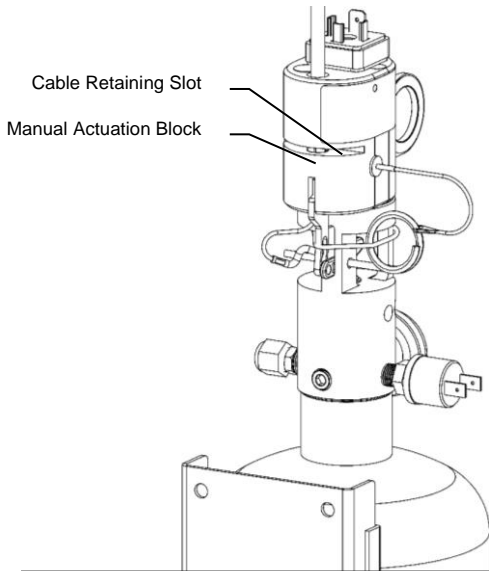

Insert extinguisher end of Cable through hole in Manual Actuation Block past retaining slot on Cable.

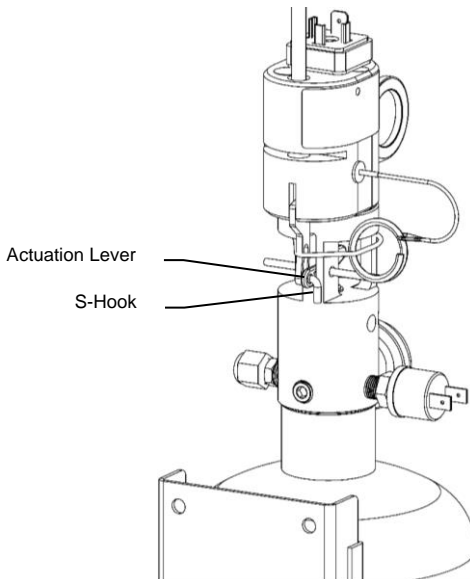

Insert S-Hook into hole of Actuation Linkage and Actuation Lever.

Connecting Cable to Cylinder Continued

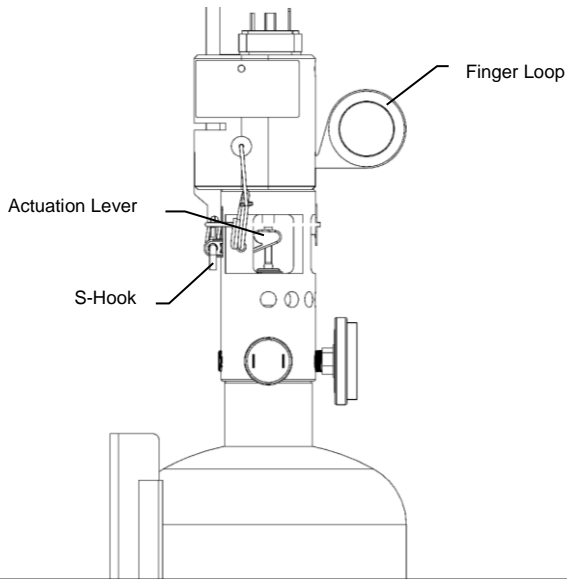

Align retaining slot of Cable with retaining slot of Manual Actuation Block.

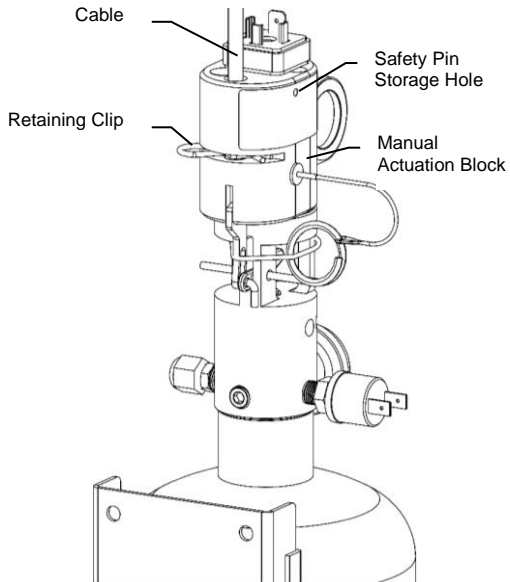

Secure Cable into Manual Actuation Block with Retaining Clip.

DANGER:

ACCIDENTAL DISCHARGE DURING HANDLING, INSTALLATION OR INSPECTION MAY CAUSE SERIOUS INJURY. WEAR EYE PROTECTION WHEN INSTALLING OR SERVICING FIRE EXTINGUISHER OR DISCHARGE CABLE.

Inspect manual discharge cable annually when inspecting the fire extinguisher.

1. Do not remove the safety pin on the T-handle when disconnecting the manual discharge cable from the fire extinguisher valve.
2. Carefully reinstall Safety Pin through actuation lever. Safety pin should secure actuation lever in Valve Body. (See Page 13) Removing the Safety Pin from the Storage Hole will cause a "Releasing Trouble" at the Release Panel.
3. Remove the retaining clip securing the cable located at the slot in the top of the manifold. (See Page 30)
4. Carefully push the cable from the backside of the manifold towards the Actuation Lever far enough to allow the flexible center strand to bend.
5. Remove the "S" hook from the actuation lever.
6. Once the "S" hook is free of the actuation lever, pull the cable out and away from the manifold.

To reconnect the manual discharge cable to the cylinder, refer to "Connecting Cable to Cylinder" section of this manual.